



1.5 – LED STRIP LIGHTS

PRODUCT INFORMATION SHEET



APPLICATIONS

- Vehicles
- Camping
- All 12V DC Applications
- Motorcycles
- Boats

FEATURES

- Cool White Flexible LED Strip Light
- 60 LED's per meter
- SMD3528 – 4.8 Watt per meter
- 120° Viewing Angle
- Low, Efficient Power Consumption
- IP66 – Dust Proof & Water Jet Resistant
- Input Voltage 12V DC
- Trim to Length
- 10mm Wide x 3mm Thick
- Peel and Stick backing with 3M adhesive



1.5 – LED STRIP LIGHTS

PRODUCT INFORMATION SHEET



SPECIFICATIONS

Part Number	LS-CW-50CM	Warranty	1 Year - Limited*
Description	Flexible Light Strip	Colour	Cool White
Length	50 centimeters	Quantity of LED Lights	30
Weight	30g	Power Consumption	2.4W (4.8W per meter)
Dimensions	10mm wide x 3mm thick		

Part Number	LS-CW-1M	Warranty	1 Year - Limited*
Description	Flexible Light Strip	Colour	Cool White
Length	1 meter	Quantity of LED Lights	60
Weight	50g	Power Consumption	4.8W (4.8W per meter)
Dimensions	10mm wide x 3mm thick		

Part Number	LS-CW-5M-REEL	Warranty	1 Year - Limited*
Description	Flexible Light Strip	Colour	Cool White
Length	5 meters	Quantity of LED Lights	300
Weight	210g	Power Consumption	24W (4.8W per meter)
Dimensions	10mm wide x 3mm thick		



1.5 – LED STRIP LIGHTS

PRODUCT INFORMATION SHEET

INSTALLATION

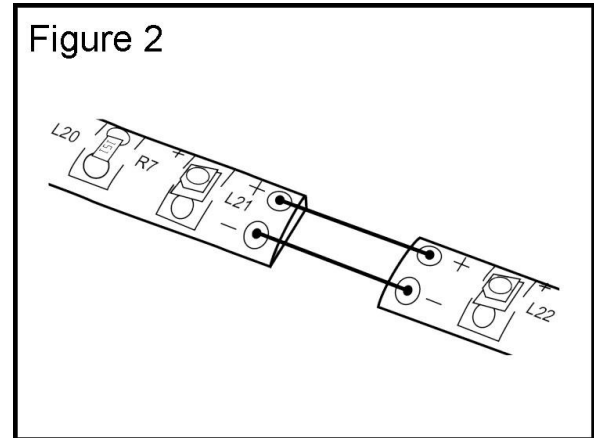
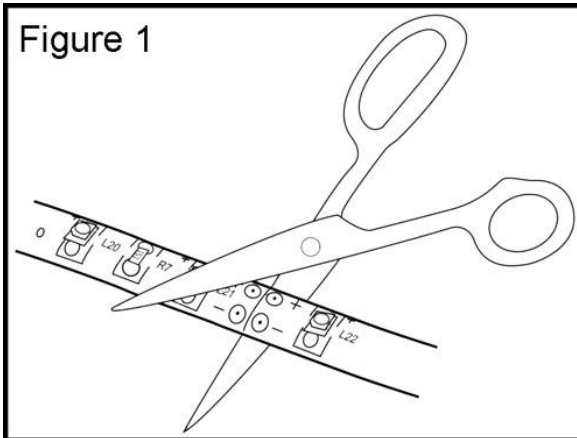

Instructions

1. Clean Surface with acetone or white spirits (surface must be smooth for good adhesion).
2. Trim lights to length as required by cutting in between the 4 dots (Figure 1), refer to 2a below for wiring multiple strip locations together.
3. Run wires back to the 12V DC power source.
4. Attach wires to the mounted surface to ensure they do not weigh on the adhesive strip.

Supplement Instructions

- 2a. Clean adhesive from back of contact pads.
- 2b. Ensure cut edges are resoldered in correct numerical order.
- 2c. Solder contact pads from each piece together noting correct polarity (Figure 2 + to+ and – to –).
- 2d. Insulate the exposed wire with epoxy and shrink wrap.



1.5 – LED STRIP LIGHTS

PRODUCT INFORMATION SHEET

WARRANTY

Kingsley Enterprises Pty. Ltd. (the 'Seller') warrants the components of the LED Strip Lights will be free from defects in materials and workmanship for a period of one (1) year from the original date of purchase.

To obtain warranty service, the Purchaser under this Limited Warranty is requested to report to the Seller or their authorised distributors of any claims. The Purchaser must provide a copy of the original proof of purchase bearing the date of purchase. Any product that the Seller determines to be defective will be repaired or replaced at Sellers sole discretion without charge to the Purchaser upon the Purchasers compliance with the above conditions. The Seller or its authorised distributors may make reasonable charges for parts and labour for repairs that are not covered by this Limited Warranty.

The Seller takes responsibility for all parts and components to be free from defects in materials and workmanship but the following are hereby disclaimed:

- a) All claims in respect to the installation.
- b) All claims in respect to water/moisture damage or overload.
- c) All claims in respect to adhesion failure.
- d) All claims in respect to rewiring.
- e) All claims for consequential or incidental damages – personal and/or property.

The Limited Warranty does not cover any failure that results from improper installation, operation or modification by the Purchaser. The Seller reserves the right to change the product design without notice. In situations in which the Seller has changed the product design, the Seller shall have no obligation to upgrade or otherwise modify previously manufactured products.

This warranty statement does not affect the purchaser's statutory rights that cannot be waived or limited by contract.